

# RainSoft®

*Environmental Products for the Home ...since 1953*

## EC4 OXYTECH Chemical-free iron, sulfur and manganese reduction WATER TREATMENT FILTER

# Owner's Manual



This product is manufactured in an ISO 9001:2000 certified facility.



Models EC4 OxyTech 150 MM, EC4 OxyTech 150 Plus MM, EC4 OxyTech 250 MM conform to WQA S-200 for the specific performance data claims as verified and substantiated by test data. See the performance data sheet for specific reduction claims.

# Table of Contents

Application Limitations .....	3
Operational Specifications .....	3–4
System Alarms .....	4
Maintenance Requirements .....	4
Product Certification Information.....	4
Installation Instructions .....	5–11
System Start Up.....	12
Understanding the Customer Settings .....	13
Programming the Customer Settings .....	14–15
Understanding a Manual Regeneration.....	16
System Alarms .....	15
Understanding the Information Center .....	17
Exploded Views and Parts Lists.....	18–23
Troubleshooting Guide .....	24
Warranty Information .....	25

**Congratulations** on your purchase of a RainSoft water treatment system!

This Owner's Manual is designed to assist with the operation, maintenance, and installation of your water treatment system. It is our sincere hope that this manual is clear, concise, and helpful to you as a new owner.

**Questions?** If you have any questions regarding the installation, operation, or servicing of this system, please contact your local RainSoft Dealer. Your local RainSoft Dealer is familiar with your particular water conditions, and is able to address your concerns promptly and efficiently.

## Application Limitations

**pH:** The influent water must be between 6.8 and 9.0.

**Iron:** Third party testing conducted at 3.7 ppm of ferrous (clear water) iron. If iron is present, the pH should be below 8.5.

**Iron Bacteria:** If iron bacteria are present, frequent service may occur and the life of the system may be limited. By properly controlling the iron bacteria with chlorine or other approved methods for bacterial reduction, the system will function properly.

**Hydrogen Sulfide:** Third party testing conducted at 1.1 ppm.

**Manganese:** Third party testing conducted at 1.68 ppm at an average pH of 8.6; amounts over 1.68 ppm may gradually prevent iron removal. For optimum manganese reduction, the pH should be between 8.0 and 9.0. If iron is also present, the pH should be below 8.5.

**Organic Matter (Tannins):** The presence of organics above 2.0 ppm may hinder the operation of the system.

**Chlorine:** The presence of chlorine in the raw water supply should be limited to a maximum of 1.0 ppm.

## Operational Specifications

**Plumbing:**  $\frac{3}{4}$ " to  $1\frac{1}{4}$ "

**Drain Line:**  $\frac{1}{2}$ "

**Water Pressure:** 20 psi–120 psi (137.89 kPa–827.37 kPa)

**Actual Influent Flow Rate:** (Water available from well pump, service inlet, etc.) The actual flow rate must exceed 5 gallons per minute. Failure to backwash the system at a rate of 5 gallons per minute (for 150 Models) or 9 gallons per minute (for 250 Models) will inhibit the filter's ability to perform as designed.

**Service Flow Rates:** See the data chart on page 4 for maximum service flow rates.

**Operating Temperatures:** 40°F–100°F (4.4°C–37.8°C)

**Electrical Requirements:** A properly grounded, alternating current supply (110 VAC 60 Hz or 230 VAC 50 Hz) is required for operation.

**Bypass Valve:** The manually operated bypass valve enables the system to be isolated from the water service line for maintenance, service, and outdoor water use. It also maintains the continuity of the water supply when the system is disconnected.

**! Important Note:** Higher pH conditions may cause the formation of colloidal iron, which is very difficult to remove.

**📎 Helpful Tip:** The maximum service flow rate is for continuous flow, not peak flow.

**! Important Note:** This system requires the use of the supplied 24 VAC transformer.

**Existing Plumbing Conditions:** Plumbing should be free from lime and/or iron buildup. Piping that contains large amounts of lime and/or iron should be replaced.

### Additional Specifications

- Do not install this system where water is microbiologically unsafe or of unknown quality without adequate disinfection before or after the system.
- This system must be installed in accordance with all applicable state and local laws and regulations.
- This system must be installed in an area not affected by extreme heat, cold, or the elements. The selected installation area must be adequate for easy service and accessibility.
- The installation must be on a cold water supply.
- Use of grounding clamps/wires required when installed on metallic pipes.

### Data Chart

MODEL	CAPACITY (GALLONS)	MAXIMUM SERVICE FLOW RATE	BACKWASH RATE
EC4 OXYTECH 150 MM	700	5.0 GPM	5.0 GPM
EC4 OXYTECH 150 PLUS MM	700	6.0 GPM	5.0 GPM
EC4 OXYTECH 250 MM	1150	7.0 GPM	9.0 GPM

## System Alarms

Your system is equipped with two alarms: **maintenance required** and **replace the filter media**. When the alarms sound, please follow the on-screen prompts and contact your local RainSoft Dealer at the service number provided. To silence the alarms, press any key on the computer.

## Maintenance Requirements

### Cleaning the Valves Annually

Your system will sound an alarm when this service is required. Please follow the on-screen prompts and contact your local RainSoft Dealer at the service number provided.

### Replacing the Filter Media Every Three to Five Years

Your system will sound an alarm when this service is required. Please follow the on-screen prompts and contact your local RainSoft Dealer at the service number provided.

 **Helpful Tip: Systems used for treatment of high iron or hydrogen sulfide will require annual maintenance.**

 **Helpful Tip: Systems used for treatment of high iron or hydrogen sulfide will require replacement of the filter media every three to five years.**

## Product Certification Information

The EC4 OxyTech units conform to WQA S-200 for iron, hydrogen sulfide, and manganese reduction as verified and substantiated by test data.

Water treatment devices sold to retail consumers in California, accompanied by certain health claims, must be certified by the State of California Department of Health Services. This product is not certified in the State of California for the purpose of making health claims.

# Installation Instructions

## 1. Safety Precautions

- To prevent accidents/injuries, do not hoist the system over your shoulder; use a hand truck.
- Do not lay the system on its side.
- Wear safety glasses and work gloves during installation and service.

## 2. Test the Raw Water Supply

- Test the raw water supply to ensure it meets the “Application Limitations” on page 3.

## 3. Check the Well Pump Flow Rate

- With no water running in the system, open a faucet and let the water run. When the pump motor starts, note the time and close the faucet. When the pump motor stops, record the time in seconds.
- Run water into a measured container (pail with markings, gallon jug, etc.) until the pump starts. Record the number of gallons in the container.
- Divide the gallons of water in the container by the number of seconds the pump ran. This number is your gallons per second. (The number should be less than one.)
- To calculate the gallons per minute, multiply the gallons per second by 60. Repeat this procedure at least three times to obtain the average well pump flow rate.

## 4. Locate a Site for the System

- The installation site must have a level, smooth, and clean surface (see Figure 1).

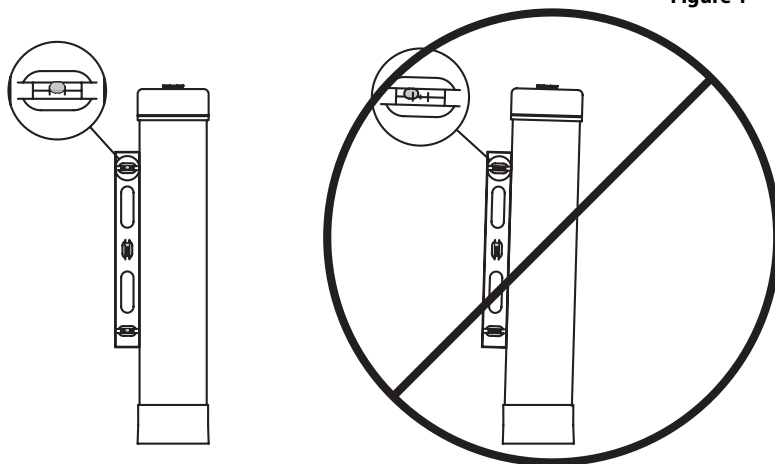

- The two tanks should be installed after the pressure tank and as close to each other as practical.
- If the system is located outdoors, protect it from direct sunlight; direct sunlight can damage the fiberglass and other system components. If necessary, build a box or shed.

**! For Massachusetts Residents only:** The Commonwealth of Massachusetts Plumbing Code 248 CMR shall be adhered to. A licensed plumber shall be used for this installation.

**! Important Note:** The well pump flow rate must exceed the recommended backwash flow rate of 5 gallons per minute (150 Models) or 9 gallons per minute (250 Models) for the system to clean effectively. Failure to properly backwash the system will result in premature system failure.

**☐ Example:** The water measurement is 6.5 gallons and the pump time is 40 seconds.  
 $6.5 \text{ gallons} / 40 \text{ seconds} = 0.1625 \text{ gallons per second}$   
 $0.1625 \text{ gallons per second} \times 60 \text{ seconds} = 9.75 \text{ gallons per minute}$   
For this example, the well pump flow rate is 9.75 gallons per minute.

**! Important Note:** The system can only be installed outdoors in climates that do not reach freezing levels.

### 5. Fill the Filter Tank with Media

- Remove the cap plugs from both tanks.
- Pull up on the riser pipes and inspect the distributors. The filter tank will have a screen distributor (see Figure 2) and the aeration tank will have an open distributor (see Figure 2). **WARNING! THE RISER PIPES ARE NOT INTERCHANGEABLE.**

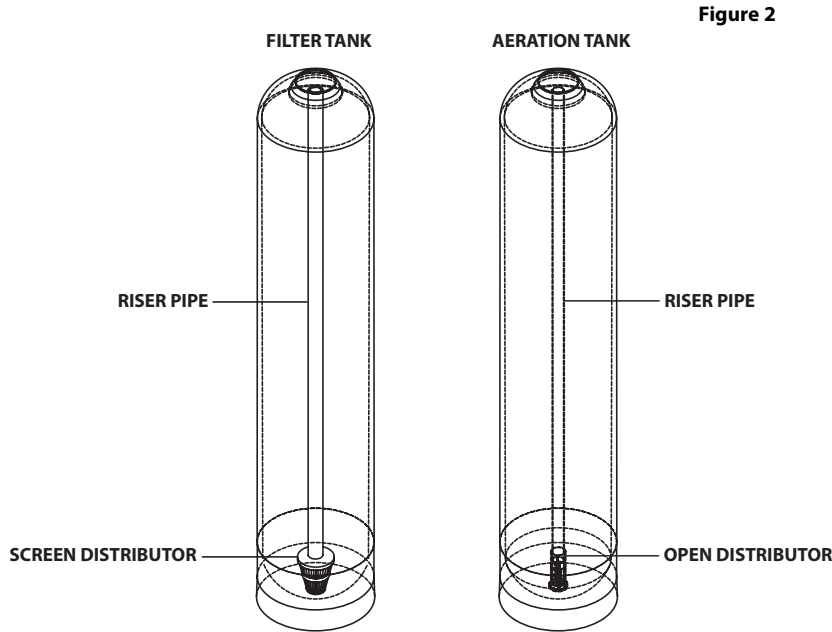

- Close off the top of the filter tank riser pipe (see Helpful Tip).
- With the funnel provided, add fills 1–4 to the filter tank (see Figure 3). Before adding each fill, move the filter tank from side-to-side to evenly distribute the media.

 **Helpful Tip:** This will prevent media from entering the riser pipe.

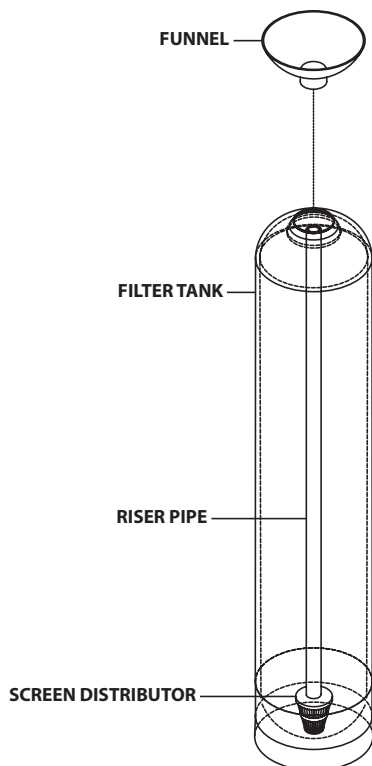

## 6. Install the Control Valves

- Lubricate the riser pipe O-rings and tank O-rings with Dow 111 silicone-based lubricant or equivalent.
- Align the filter control valve with the screen distributor riser pipe (see Figure 4). Push down on the filter control valve and continue to turn it clockwise until the valve O-ring seals against the filter tank. **WARNING! THE CONTROL VALVES ARE NOT INTERCHANGEABLE.**
- Align the aeration control valve with the open distributor riser pipe (see Figure 4). Push down on the aeration control valve and continue to turn it clockwise until the valve O-ring seals against the aeration tank. **WARNING! THE CONTROL VALVES ARE NOT INTERCHANGEABLE.**

**! Important Note: Do not over-tighten the control valves to the tanks.**

**! Important Note: The filter control valve (with the computer) must be installed on the media filter tank (see Figure 4).**

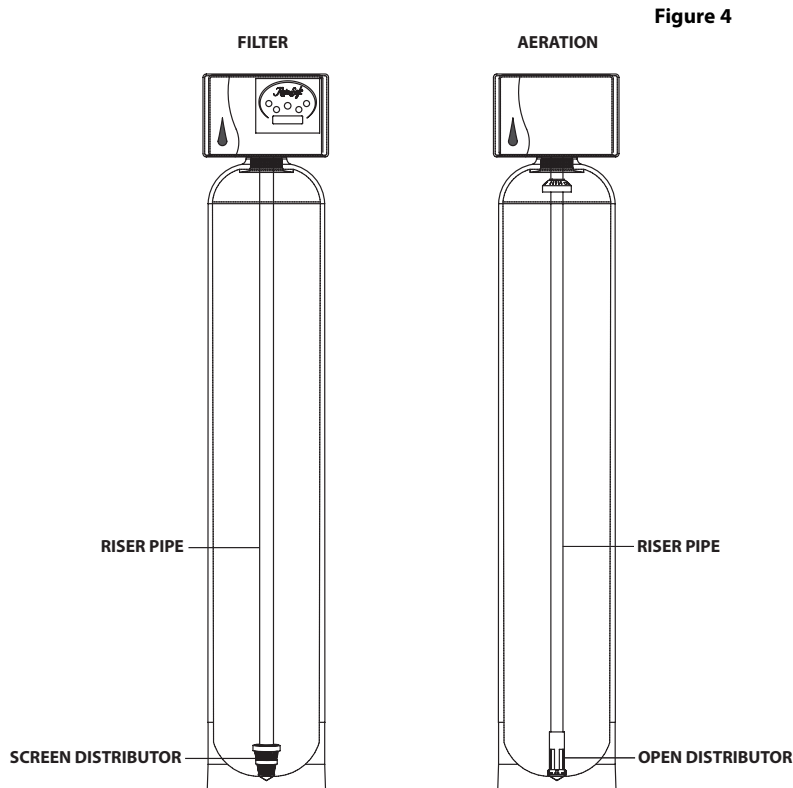

## 7. Turn Off the Water and Drain the Plumbing

- Turn off the water at the meter or the pressure tank.
- Open all faucets and flush the toilets. The water will drain out of the lowest faucet or outlet and air will enter the plumbing system.

## 8. Bypass the Outside Faucet(s)

- Install plumbing pipes to bypass the outside faucet(s). If the plumbing is not accessible, provide an untreated hose bib on the inlet pipe.

### 9. Install the Check Valve

- Install the supplied 1" check valve on the raw water supply feeding the aeration tank (see Figures 5.1 & 5.2). The check valve must be installed in vertical, upflow position with a minimum 12" water column above the check valve (see Figures 5.1 & 5.2).

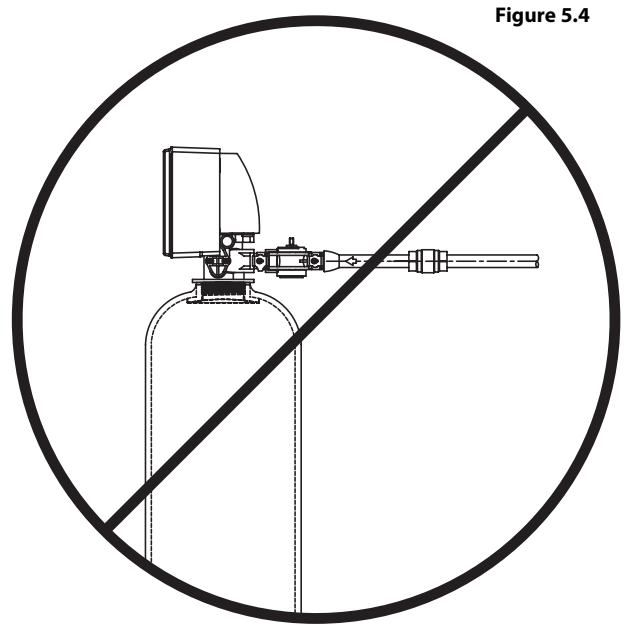
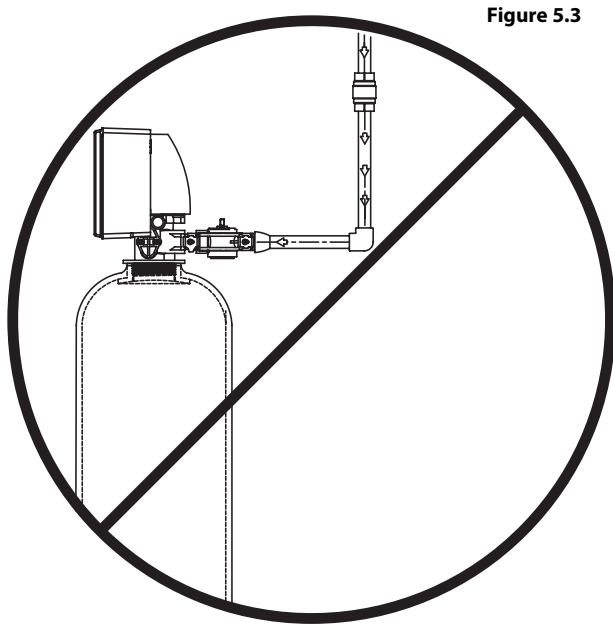
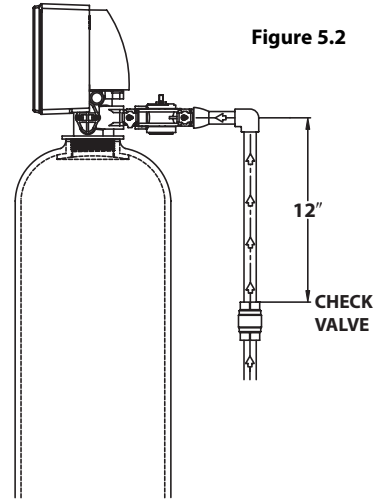
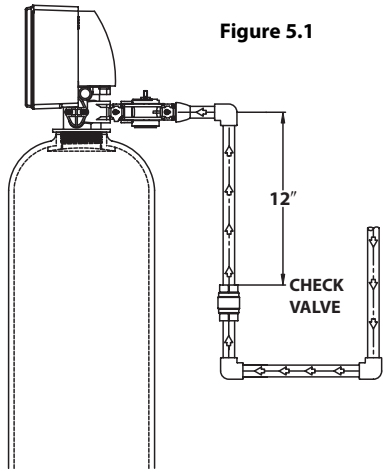

## 10. Connect the Plumbing

- Connect the check valve outlet to the aeration tank inlet (see Figure 6).
- Connect the aeration tank outlet to the filter tank inlet (see Figure 6). Use 1" diameter pipe between the aeration tank and filter tank.
- Connect the filter tank outlet to the house plumbing (see Figure 6).

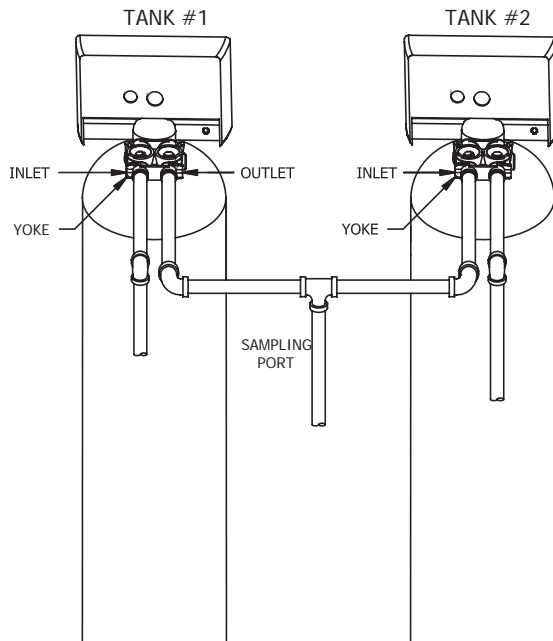

Figure 6

**Important Note:** All RainSoft systems require a yoke to connect the plumbing to the bypass valve.

**Helpful Tips:** Do not sweat pipes with water in them or while attached to the system; steam will damage the plastic parts in the valves.

Do not point the soldering torch directly at the tanks or valves. These composite materials will last a lifetime, but cannot withstand the intense heat from a torch.

Avoid short connections of pipe between the system outlet and the water heater inlet. If you can't avoid a short connection, move the system to another location. As a last resort, install a heat trap or check valve. If this causes "water hammer", install a "water hammer" suppressor.

## 11. Bypass Both Systems

- Move the bypass valve handles to the bypass position. The bypass valve handles should be perpendicular to the pipes (see Figure 7).

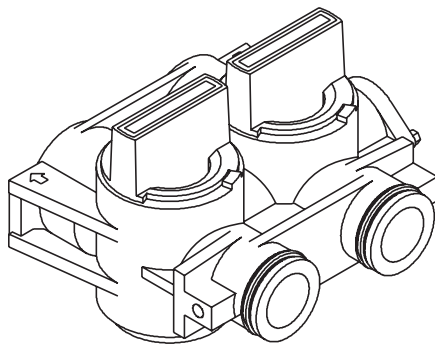

Figure 7\*

\* Complete system not shown

## 12. Install the Drain Lines, Air Check Valve Assembly, and Air Gap

- Connect 1/2" I.D. drain line to the drain outlet of both valves; outlet side (see Figure 8). Use the supplied elbows and spring clips.

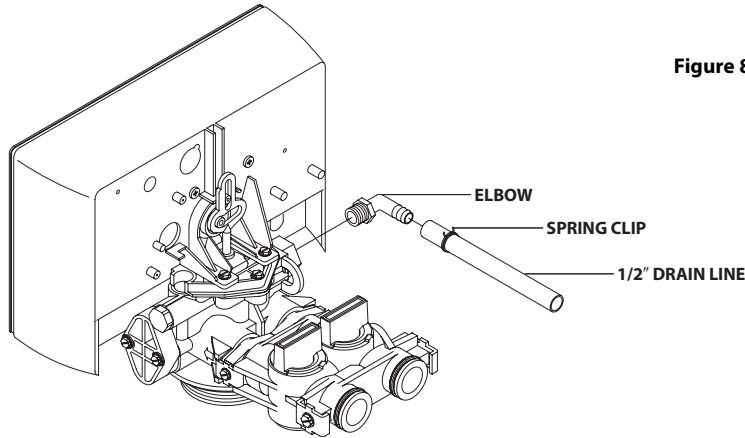

Figure 8\*

**Helpful Tips:** The aeration drain line can tee into the drain line of the filter or to an approved independent drain. The drain line emits surges of excess air from the aeration tank and must be secured.

\* Complete system not shown

- Place the ferrule inside the brass nut and screw the brass nut onto the brass adapter of the aeration valve; inlet side (see Figure 9).
- Assemble the air check valve assembly in this order: elbow, pvc tubing, air check valve with molded arrow pointing down, pvc tubing, and air in-take screen (see Figure 9). After assembly, push the elbow into the brass adapter (see Figure 9).

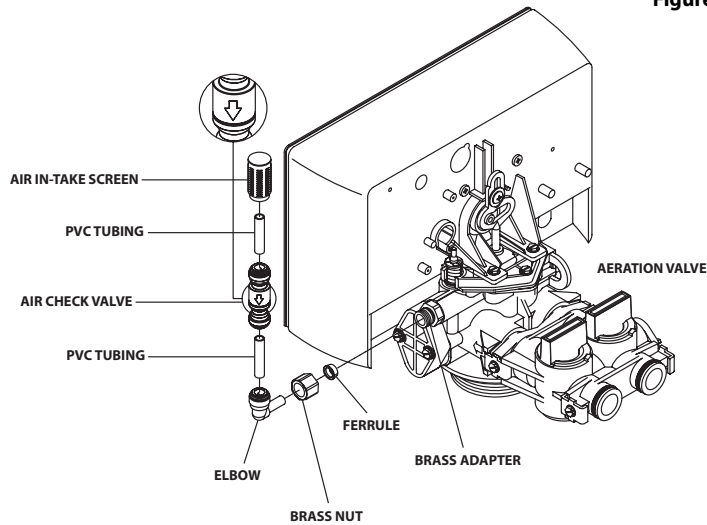

Figure 9\*

\* Complete system not shown

- Run the drain lines to an approved air gap and drain (see Figure 10).

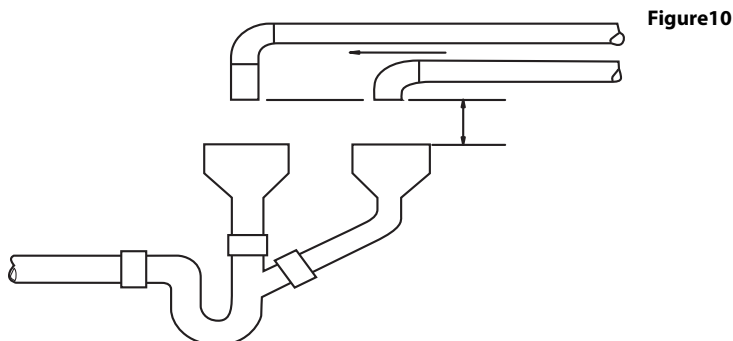

Figure 10

**Helpful Tips:** The drain line emits surges of excess air from the aeration tank and must be secured.

### 13. Create the Electrical Connections

- Attach the U-shaped connectors to the 18/2 gauge wire with a crimping tool (see Figure 11). If the 18/2 gauge wire is too short, use the connectors and shrink tubing to lengthen the wire (see Figure 11).
- Connect the 18/2 gauge wire to the transformer (see Figure 11). Insert the other end of the 18/2 gauge wire (with the connector) into the back of the filter control box (see Figure 11).

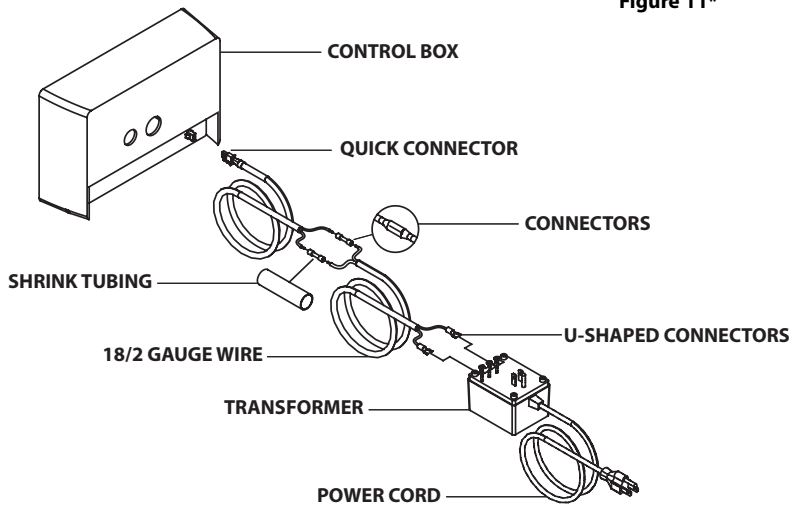

Figure 11\*

! Important Notes: 18/2 gauge wire (part number 18566) must be used; do not use bell wire.

• On outdoor applications, shrink tubing must be used to prevent the wires from corroding.

\* Complete system not shown

- Use the jumper wire to connect the two systems together (see Figure 12). One way connection only.

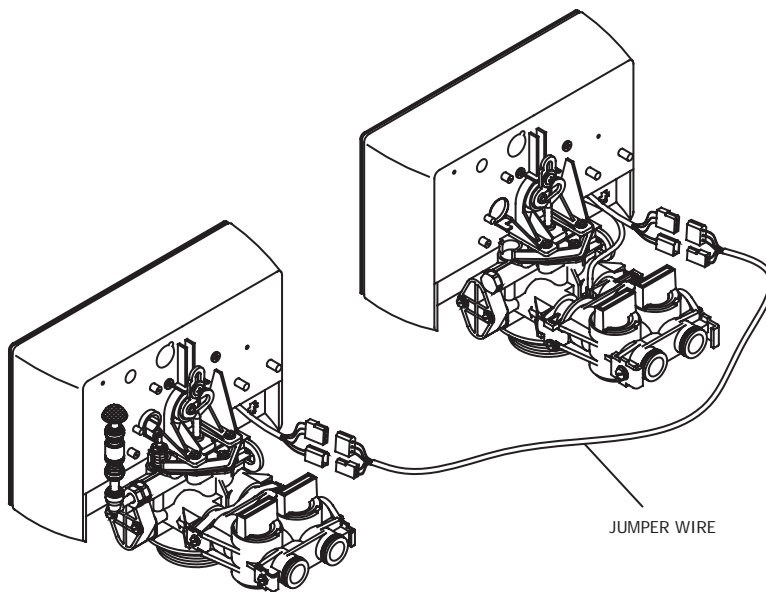

Figure 12\*

! Important Note: On outdoor applications, shrink tubing must be used to prevent the wires from corroding.

\* Complete system not shown

- Plug the 24VAC transformer into a 110 VAC 60 Hz or 230 VAC 50 Hz outlet.

The installation is complete. Please proceed to "System Startup" on page 12.

## System Startup

- Close all faucets and turn the water back on at the water meter or pressure tank.
- Check for leaks. If a leak is present, drain the plumbing again before soldering.
- Open a cold water faucet and allow the water to run for a few minutes or until all foreign material from the installation is washed out; keep faucet open.
- Move the filter and aeration bypass valve handles to the service position (see Figure 13) and allow water to fill both tanks.

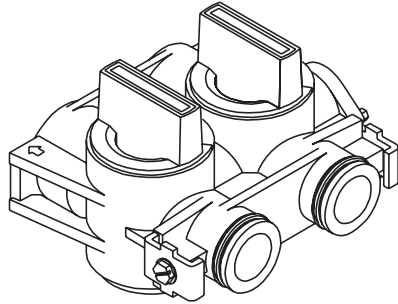



Figure 13\*

 **Helpful Tip: Air will purge at this time.**

\* Complete system not shown

- Allow the water to run for a few minutes until clear; close the faucet.
- Press the **Manual Regeneration key** on the computer; the control will display:

**MANUAL REGEN. FILTER AIR BOTH?**

- Press the **Menu Forward key** to select **Air** and then the **Enter key**; the control will display:

**AIR TANK REGEN. NOW OR LATER?**

- Press the **Enter key** to select **NOW**; the computer will provide a 10 second countdown before regeneration.
- During regeneration, the aeration system will purge water from the aeration tank and then fill with air. While the aeration system is purging, inspect and secure all drain connections.
- When the regeneration is complete, open all faucets in the house and allow the water to run for a few minutes until clear; close all faucets.

**WARNING! DO NOT BACKWASH THE FILTER SYSTEM FOR 24 HOURS.**

**The system startup is complete. Please proceed to “Customer Settings” on pages 13–16.**

 **Helpful Tip: The computer is located on the filter control valve.**

 **Helpful Tip: The drain line emits surges of excess air from the aeration tank and must be secured.**

# Understanding the Customer Settings

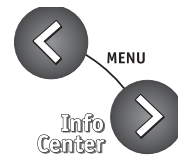

**Menu Forward and Menu Back keys:** Use to scroll through the list of functions or to change the menu choice.

**Info Center key:** Use to access the Information Center.

Manual Regeneration



**Manual Regeneration key:** Use to initiate a manual regeneration.

**Enter key:** Use to select or enter the menu of choice.

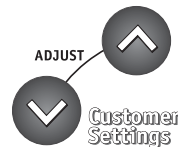

**Adjust Up and Adjust Down keys:** Use to alter the blinking value.

**Customer Settings key:** Use to access the Customer Settings.

## Programming Options

**Vacation Mode:** Puts the system into hibernation while you are on vacation or gone for extended period of time.

**System Alarm:** Sets the audio alarm to "ON/OFF" and the time it will sound. The default setting for "ON" is 5:00 P.M.

**Time of Day:** Sets the current time of day.

**Current Day:** Sets the current day of the week.

**Current Date:** Sets the current date by month/day/year.

**Auto Daylight Savings Time:** Allows the computer to automatically adjust for daylight savings time in applicable areas. The default setting is "ON".

**Filter Schedule WK1/WK2:** Sets the days of the week that the filter will clean. The default setting is every other day, starting with Sunday.

**Time of Filter Regeneration:** Sets the time of day (only on the hour) that the filter will regenerate/clean. The default setting is 11:00 P.M. We recommend that you do not change the default setting. Changing the default setting may interfere with other RainSoft products. The filter and air regenerations should not be set for the same time of day.

**Time of Air Regeneration:** Sets the time of day (only on the hour) that the computer will replenish the air pocket. The air default setting is 1:00 A.M. We recommend that you do not change the default setting. Changing the default setting may interfere with other RainSoft products. The filter and air regenerations should not be set for the same time of day.

**Number of Air Purges:** Sets the number of times the air will purge and replenish per day. The default setting is one purge at 1:00 A.M. One purge = every 24 hours; Two purges = every 12 hours; Three purges = every 8 hours; Four purges = every 6 hours.

# Programming the Customer Settings

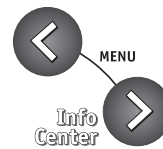

**Menu Forward and Menu Back keys:** Use to scroll through the list of functions or to change the menu choice.

**Info Center key:** Use to access the Information Center.

**Manual Regeneration**



**Manual Regeneration key:** Use to initiate a manual regeneration.

**Enter key:** Use to select or enter the menu of choice.

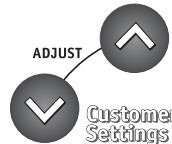

**Adjust Up and Adjust Down keys:** Use to alter the blinking value.

**Customer Settings key:** Use to access the Customer Settings.

If the display is not lit, press any key to begin. When the display is lit, press the **Customer Settings key**; the computer will display:

VACATION SET: OFF

- To leave this setting **OFF**, press the **Menu Forward key** to advance to **SYSTEM ALARM**.
- To select **ON**, press the **Adjust Up** or **Adjust Down key**; the computer will display:

VACATION SET: ON DAYS AWAY: 2

- Press the **Menu Forward key** to access the days away.
- Use the **Adjust Up** and **Adjust Down keys** to change the number of days away, if desired.
- Press the **Menu Forward key** to advance to **SYSTEM ALARM**; the computer will display:

SYSTEM ALARM: OFF

- To leave this setting **OFF**, press the **Menu Forward key** to advance to **TIME OF DAY**.
- To select **ON**, press the **Adjust Up** or **Adjust Down key**; the computer will display:

SYSTEM ALARM: ON SET FOR 5:00 P.M.

- Press the **Menu Forward key** to access the system alarm time.
- Use the **Adjust Up** and **Adjust Down keys** to change the system alarm time, if desired.
- Press the **Menu Forward key** to advance to **TIME OF DAY**; the computer will display:

TIME OF DAY

- Use the **Adjust Up** and **Adjust Down keys** to change the hour of day.
- Press the **Menu Forward key** to access the minutes of day. Use the **Adjust Up** and **Adjust Down keys** to change the minutes.

**! Important Notes:** After setting the vacation mode, the computer will provide a 16 hour delay for your convenience. If water use is detected after the 16 hour delay, the vacation mode is deactivated. One day prior to the scheduled return, the system will regenerate at the normal regeneration time. This feature will ensure a fresh, clean system upon your arrival.

- Press the **Menu Forward key** to advance to **CURRENT DAY**; the computer will display:

CURRENT DAY

- Use the **Adjust Up** and **Adjust Down keys** to select the current day.
- Press the **Menu Forward key** to advance to **CURRENT DATE**; the computer will display:

CURRENT DATE

- Use the **Adjust Up** and **Adjust Down keys** to change the month.
- Press the **Menu Forward key** to access the day. Use the **Adjust Up** and **Adjust Down keys** to change the day.
- Press the **Menu Forward key** to access the year. Use the **Adjust Up** and **Adjust Down keys** to change the year.
- Press the **Menu Forward key** to advance to **AUTO DAYLIGHT SAVINGS TIME**; the computer will display:

AUTO DAYLIGHT SAVINGS TIME: ON

- To leave this setting **ON**, press the **Menu Forward key** to advance to **FILTER WK1**.
- To select **OFF**, press the **Adjust Up** or **Adjust Down key**. Press the **Menu Forward key** to advance to **FILTER WK1**; the computer will display:

FILTER WK1: ON SU TU TH S

- Use the **Adjust Up** and **Adjust Down keys** to select **ON** or **OFF** for each day of the week. Use the **Menu Forward key** to advance to each day of the week.
- Press the **Menu Forward key** to advance to **FILTER WK2**; the computer will display:

FILTER WK2: ON M W F

- Use the **Adjust Up** and **Adjust Down keys** to select **ON** or **OFF** for each day of the week. Use the **Menu Forward key** to advance to each day of the week.
- Press the **Menu Forward key** to advance to **TIME OF FILTER REGEN**; the computer will display:

TIME OF FILTER REGEN: 11:00 P.M.

- Use the **Adjust Up** or **Adjust Down key** to change the hour of regeneration, if desired.
- Press the **Menu Forward key** to advance to **TIME OF AIR REGEN**; the computer will display:

TIME OF FILTER REGEN: 1:00 A.M.

- Use the **Adjust Up** or **Adjust Down key** to change the hour of regeneration, if desired.
- Press the **Menu Forward key** to advance to **NUMBER OF PURGE**; the computer will display:

NUMBER OF PURGE: 1 PER DAY

- Use the **Adjust Up** or **Adjust Down key** to change the number of air purges per day, if desired.
- Press the **Menu Forward key** to exit the Customer Settings.

 **Helpful Tip:** Use the Menu Back key to edit your selection.

 **Helpful Tip:** If auto daylight savings time is "ON", the system will automatically adjust the clock in the spring and fall. Only set the daylight savings time to "OFF" if daylight savings time is not observed in your area.

 **Helpful Tip:** We recommend the default setting of every other day.

 **Helpful Tip:** We recommend the default setting of every other day.

 **Helpful Tip:** Filter default setting is 11:00 P.M. We recommend that you do not change the default setting. Changing the default setting may interfere with other RainSoft products. The filter and air regenerations should not be set for the same time of day.

 **Helpful Tip:** Air default setting is 1:00 A.M. We recommend that you do not change the default setting. Changing the default setting may interfere with other RainSoft products. The filter and air regenerations should not be set for the same time of day.

 **Helpful Tip:** We recommend the default setting of once per day. Multiple purges per day may be required for high levels of iron or hydrogen sulfide.

# Understanding a Manual Regeneration

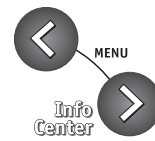

**Menu Forward and Menu Back keys:** Use to scroll through the list of functions or to change the menu choice.

**Info Center key:** Use to access the Information Center.

**Manual Regeneration**



**Manual Regeneration key:** Use to initiate a manual regeneration.

**Enter key:** Use to select or enter the menu of choice.

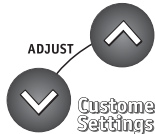

**Adjust Up and Adjust Down keys:** Use to alter the blinking value.

**Customer Settings key:** Use to access the Customer Settings.

## Manual Regeneration Options

If the display is not lit, press any key to begin. When the display is lit, press the **Manual Regeneration key**; the computer will display:

**MANUAL REGEN. FILTER AIR BOTH?**

- To select **FILTER**, press the **Enter key**; the computer will display:

**FILTER REGEN. NOW OR LATER?**

- To select **NOW**, press the **Enter key**; the computer will provide a 10 second countdown before regeneration.
- To select **LATER**, press the **Menu Forward key** and then the **Enter key**; the computer will display:

**FILTER REGEN. LATER AT (THE SET REGENERATION TIME)**

- To select **AIR**, press the **Menu Forward key** and then the **Enter key**; the computer will display:

**AIR TANK NOW OR LATER?**

- To select **NOW**, press the **Enter key**; the computer will provide a 10 second countdown before regeneration.
- To select **LATER**, press the **Menu Forward key** and then the **Enter key**; the computer will display:

**AIR REGEN. LATER AT (THE SET REGENERATION TIME)**

- To select **BOTH**, press the **Menu Forward key** 2 times and then the **Enter key**; the computer will display:

**FILTER + AIR REGEN. NOW OR LATER?**

- To select **NOW**, press the **Enter key**; the computer will provide a 10 second countdown before regeneration.
- To select **LATER**, press the **Menu Forward key** and then the **Enter key**; the computer will display:

**FILTER + AIR REGEN. LATER AT (THE SET REGENERATION TIME)**

**Helpful Tips:** To cancel a manual regeneration before the countdown reaches 0 or before the hour of regeneration occurs, press the **Menu Forward** or **Menu Back** key. To cancel a manual regeneration already in progress, press and hold the **Menu Back** key. The system will return to service automatically.

# Understanding the Information Center

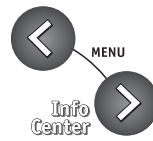

**Menu Forward and Menu Back keys:** Use to scroll through the list of functions or to change the menu choice.

**Info Center key:** Use to access the Information Center.

Manual Regeneration



**Manual Regeneration key:** Use to initiate a manual regeneration.

**Enter key:** Use to select or enter the menu of choice.

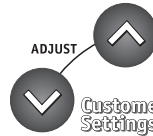

**Adjust Up and Adjust Down keys:** Use to alter the blinking value.

**Customer Settings key:** Use to access the Customer Settings.

The Information Center provides current alarm information, water usage, and general information about your system. To access this information, please follow the directions listed below.

If the display is not lit, press any key to begin. When the display is lit, press the **Info. Center key**. To view the list of diagnostics, use the **Menu Forward** and **Menu Back keys**. To exit the Information Center at any time, press the **Enter key**.

## Display Options

**Unit Size:** Displays the size of the system.

**System Status:** Displays the current status, including any alarm information.

**System Alarm:** Displays the "ON/OFF" condition and the time set to sound the alarm.

**Time of Filter Regen:** Displays the hour set for regeneration.

**Time of Air Regen:** Displays the hour set for regeneration.

**Avg. Water Use:** Displays the average water use (gallons per day).

**Current Flow Rate:** Displays the flow rate through the system when water is used (gallons per minute).

**Vacation Mode:** Displays the "ON/OFF" condition.

**OxyTech System Installed:** Displays the date of installation.

**Web Address:** Displays the RainSoft web address.

**For Service Call:** Displays the service phone number.

**! Important Note:** The Information Center is a display only mode and will not allow any changes to the settings or current service run data.

**! Important Note:** The "Average Water Use" will be accurate 7 days after startup.

# Filter Valve Exploded View

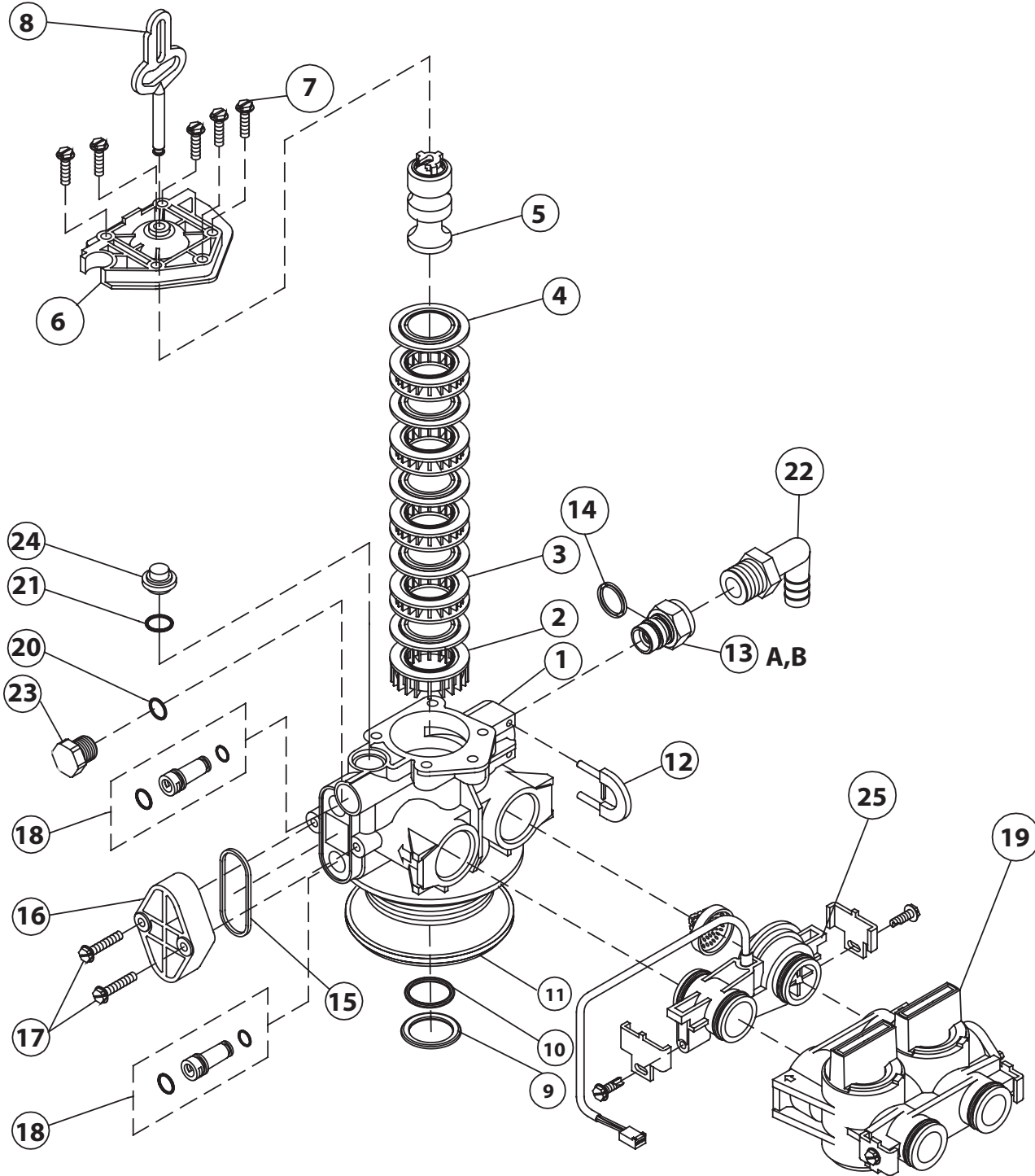

# Aeration Valve Exploded View

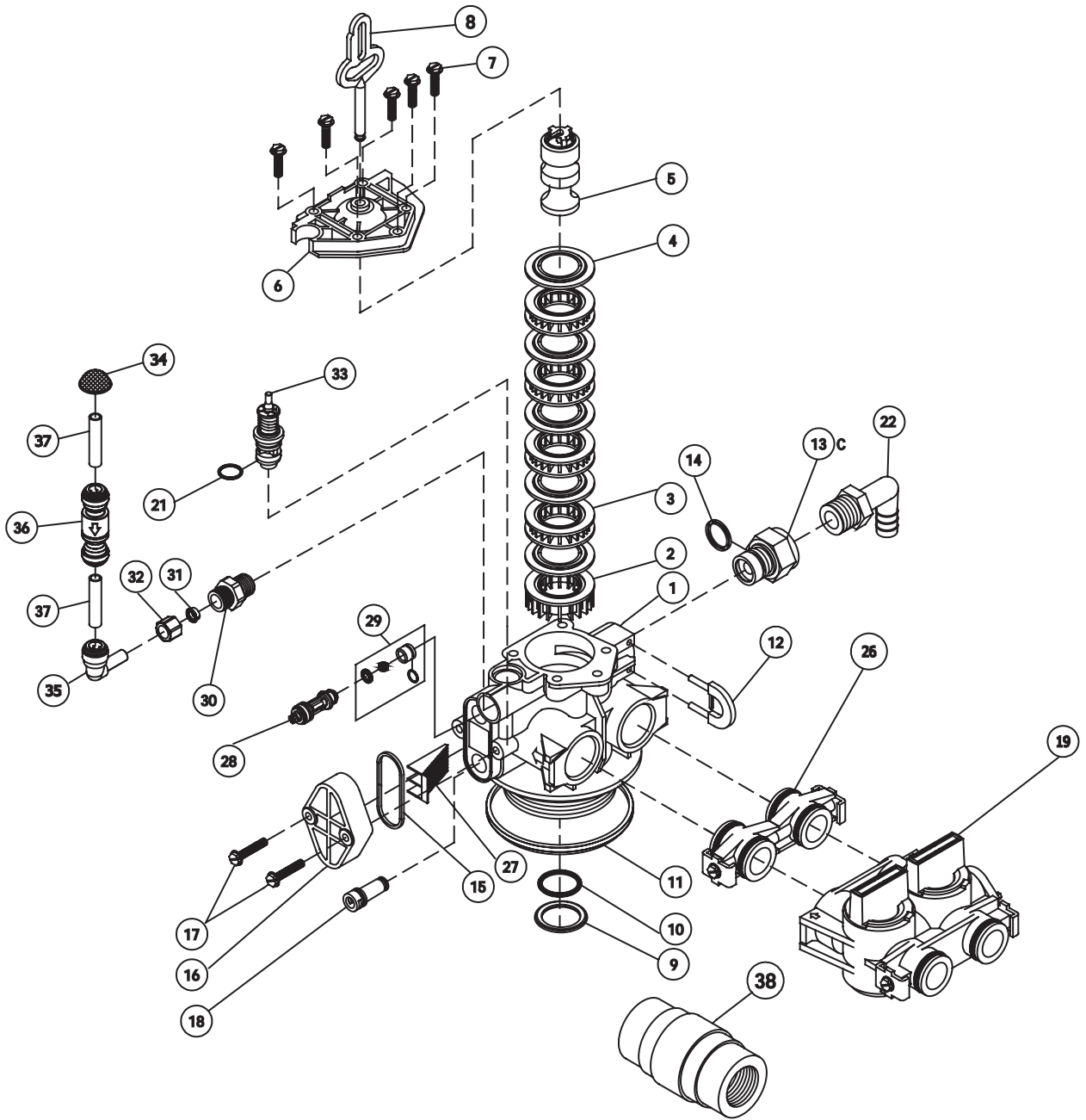

# Filter Control Exploded View

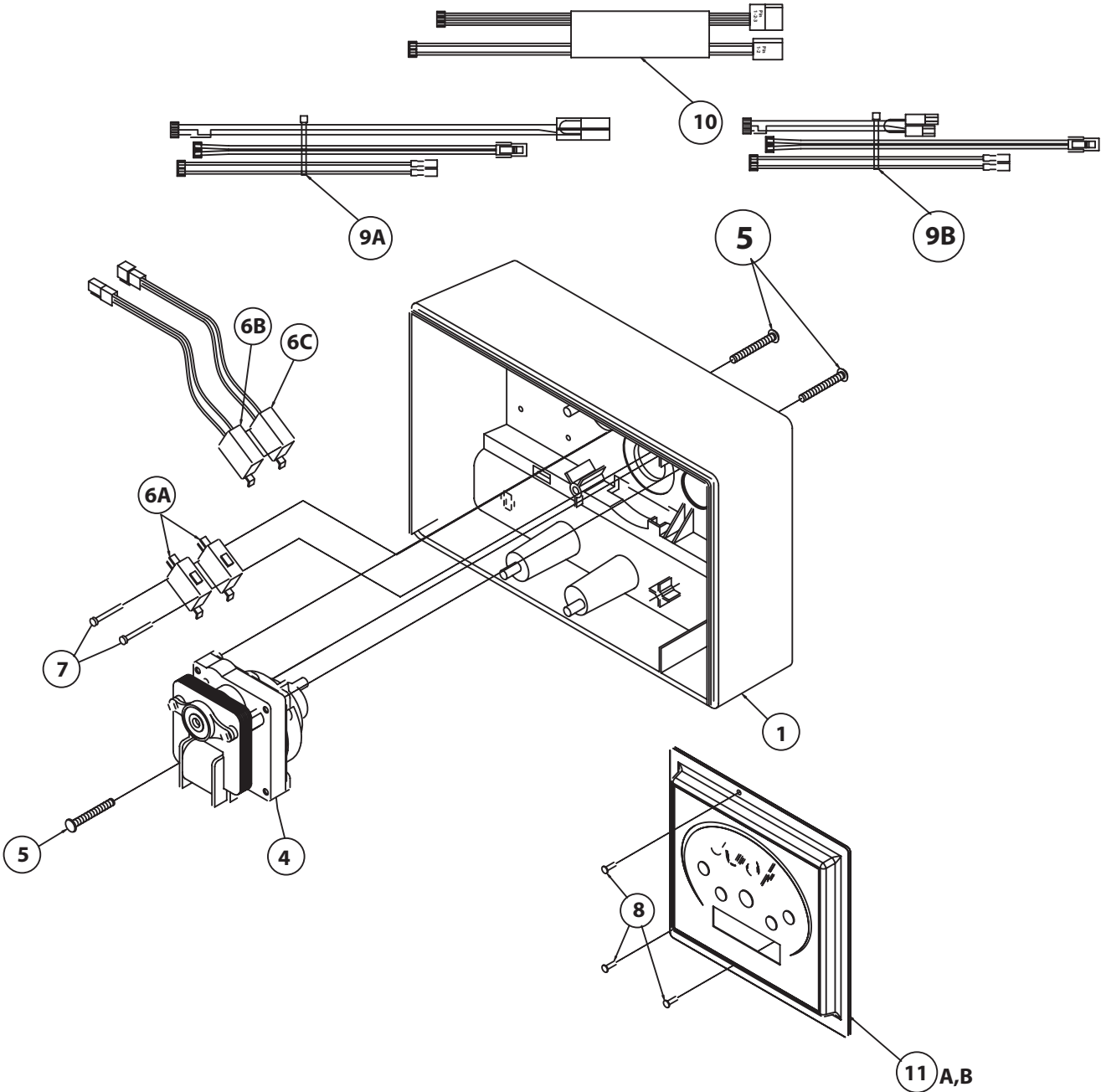

# Aeration Control Exploded View

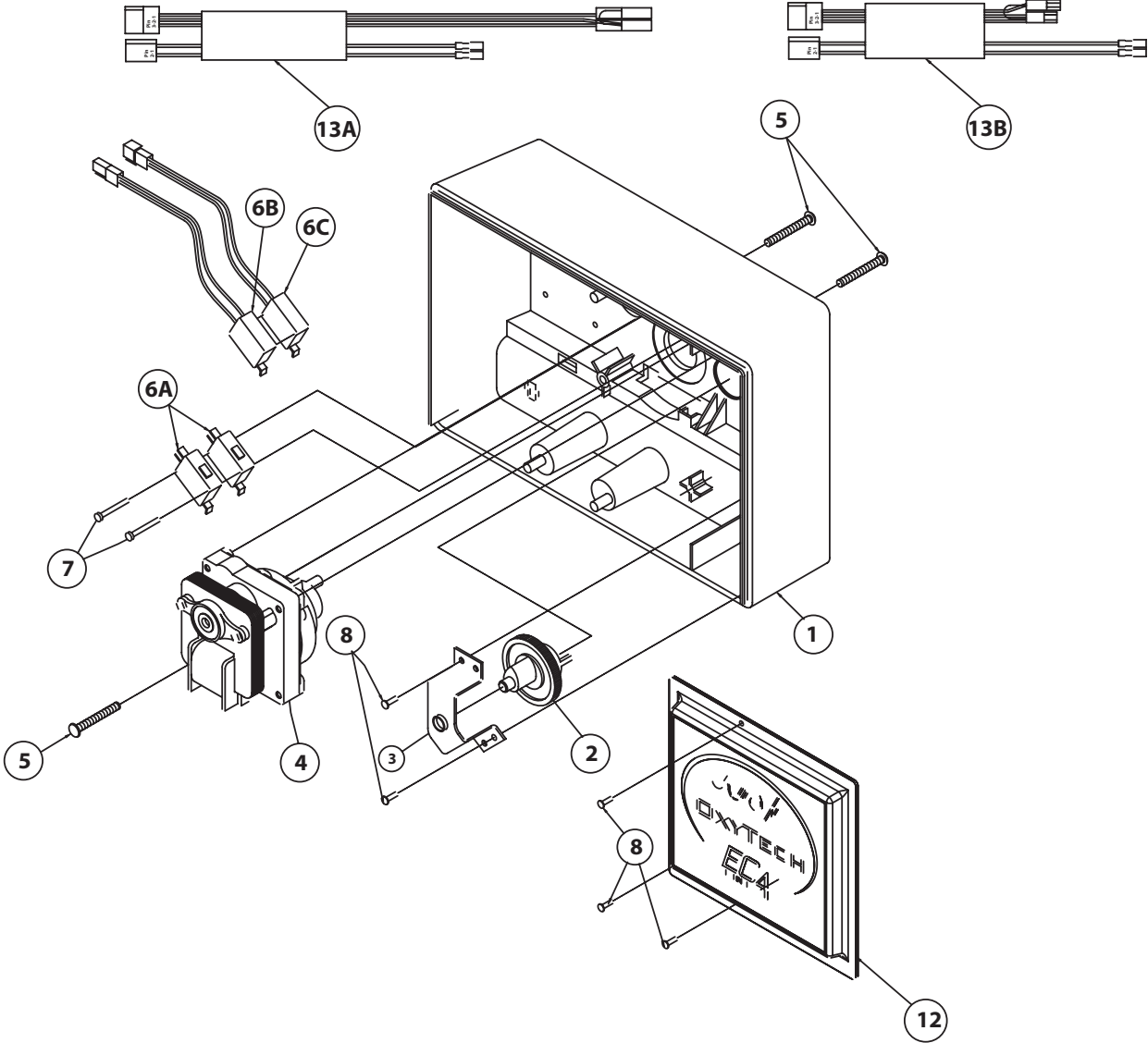

## Filter and Aeration Valve Parts List

ITEM	QUANTITY	PART NUMBER	DESCRIPTION
1	2	17863	COMPOSITE VALVE BODY FOR 1" RISER PIPE
2	2	17864	END SPACER
3	8	17865	SPACER
4	10	19860	OXYTECH SEAL
5	2	19861	OXYTECH PISTON
6	2	17869	END PLUG ASSEMBLY
7	10	17870	10-24 X .812" SCREW HEX WASHER HEAD
8	2	17871	PISTON ROD
9	2	18445	RISER PIPE RETAINER O-RING
10	2	17888	O-RING - 121
11	2	17889	O-RING - 336
12	2	17887	DRAIN RETAINER
13A	1	18267	DRAIN LINE FLOW CONTROL 5.0 ASSEMBLY
13B	1	19889	DRAIN LINE FLOW CONTROL 9.0 ASSEMBLY
13C	1	17991	DRAIN LINE FLOW CONTROL 1.5 ASSEMBLY
14	2	10258	O-RING - 017
15	2	17949	INJECTOR SEAL
16	2	17950	INJECTOR CAP, SOFTENER
17	4	17951	10-24 X 1" SCREW HEX WASHER HEAD
18	2	17617	C-INJECTOR PLUG ASSEMBLY
19	2	17557	COMPOSITE BYPASS VALVE
20	2	17958	O-RING - 015
21	2	13329	O-RING - 014
22	1	17939	1/2" NPT X 1/2" BARB POLY ELBOW
23	1	18270	FILTER PLUG
24	1	18271	BRINE VALVE PLUG
25	1	17558	COMPOSITE TURBINE METER ASSEMBLY WITH CABLE
26	1	17560	PLASTIC ADAPTER COUPLING ASSEMBLY 3/4"
27	1	17948	INJECTOR SCREEN
28	1	18194	C-INJECTOR #1 ASSEMBLY
29	1	19739	CHECK BALL CAGE ASSEMBLY
30	1	17957	BRASS ADAPTER WITH INTERNAL CHECK VALVE
31	1	14189	FERRULE
32	1	12187	BRASS COMPRESSION NUT
33	1	17812	COMPOSITE REFILL SHUT-OFF ASSEMBLY
34	1	19856	AIR IN-TAKE SCREEN
35	1	18699	ELBOW 3/8" JG STEM X 3/8" JG TUBE
36	1	19734	CHECK VALVE 3/8" AIR
37	2	18772	3/8" HARD PVC TUBING X 2.00" LONG
38	1	19736	CHECK VALVE 1" NOISELESS

## Filter and Aeration Control Parts List

ITEM	QUANTITY	PART NUMBER	DESCRIPTION
1	2	17487	REAR HOUSING
2	1	19743	BRINE GEAR/CAM, AIR
3	1	17492	BRINE GEAR BRACKET
4	2	17537	VALVE MOTOR WITH COMPUTER CAM, 24V-50/60HZ
5	6	17548	10-32 X 1-1/2 SCR.PAN. H. PHIL. MACH.SS.
6A	4	17526	SWITCH 45° ACTUATOR
6B	2	19536	SEALED SWITCH C-NC MALE CONNECTOR RED
6C	2	19537	SEALED SWITCH C-NO FEMALE CONN BROWN
7	4	18135	4 X 1-1/4 SLOTTED HEX WASHER TYPE 25
8	6	17542	4-20 X 3/8 SCR.PAN. H. PHIL.SS.
9A	1	19693	EC4 COMPUTER WIRE HARNESS
9B	1	19732	OUTDOOR EC4 COMPUTER WIRE HARNESS
10	1	19880	EC4 DUPLEX WIRE HARNESS CONTROL
11A	1	19798	EC4 OXYTECH COMPUTER ASSEMBLY
11B	1	19800	OUTDOOR EC4 OXYTECH COMPUTER ASSEMBLY
12	1	19801	EC4 OXYTECH FACE PLATE NO DISPLAY ASSEMBLY
13A	1	19881	EC4 DUPLEX WIRE HARNESS REMOTE
13B	1	19882	OUTDOOR EC4 DUPLEX WIRE HARNESS REMOTE

# Troubleshooting Guide

SYMPTOM	CAUSE	SOLUTION
<b>1. Systems fail to regenerate automatically.</b>	1. The power supply is plugged into intermittent or dead power source.	1. Connect to a constant power source.
<b>2. Systems regenerate at the wrong time.</b>	1. The computer is not set properly. 2. The time is off due to daylight savings.	1. Reset the time of day & hour of regenerations. 2. Verify that auto daylight savings time is set to "ON".
<b>3. Poor water quality.</b>	1. The raw water has changed. 2. The bypass valve is open. 3. The power supply is disconnected.	1. Call your RainSoft Dealer for a new water analysis. 2. Close the bypass valve. 3. Plug in the power supply.
<b>4. Loss of water pressure.</b>	1. Low pressure to the unit. 2. The media is exhausted or fouled.	1. Bypass the system. If the problem still exists after bypass, it is not related to a RainSoft product; check your water distribution system. If the problem is resolved after bypass, call your RainSoft Dealer for service. 3. Call your RainSoft Dealer for service. The system may need to be re-bedded.
<b>5. Continuous flow to drain.</b>	1. Foreign material in the valve. 2. Excessive water pressure.	1. Call your RainSoft Dealer to clean the valve. 2. Install a pressure regulator.
<b>6. Water is effervescent.</b>	1. Water supply has been naturally aerated under well system pressure. As water is exposed to the atmosphere, air molecules separate from the water.	1. This natural phenomenon will typically dissipate to the atmosphere in a matter of seconds. If preferred, water can be drawn and stored in an open container prior to use.

**If the troubleshooting guide did not resolve the symptom, please contact your local RainSoft Dealer for service. If you cannot locate your local RainSoft Dealer, please contact RainSoft Customer Service at 1-800-860-7638 or logon to [www.rainsoft.com](http://www.rainsoft.com) for the name and location of your nearest authorized Dealer.**

# Limited Lifetime Warranty

*For as long as you own the equipment*

*RainSoft Division of Aquion Water Treatment Products, believing its*

## **WATER FILTRATION SYSTEM**

*to be of exceptional quality, hereby warrants said equipment to its first purchaser at retail as follows:*

*The tanks and valves are warranted against defects in manufacture for the lifetime of the first purchaser at retail.*

*The electrical parts are warranted against defects in manufacture for five years and pro-rata warranted for an additional five years.*

*The potassium permanganate solution tank and internal components (F8C models only) are warranted against defects in manufacture for one year.*

*The filter media is not warranted. The filter media service life is dependent on specific water conditions and usage.*

*This warranty begins at the time the equipment is first connected for use, and is contingent upon the return of a signed owner's registration card.*

*This warranty does not require replacement of the entire unit. If the equipment does not perform properly, you should request service from the dealer that sold you the equipment. If you are not satisfied, you should notify our Customer Service Manager. If we are not able to arrange local servicing, you should send the defective part(s) (or, if you prefer, send the entire unit,) directly to the manufacturer, freight prepaid, with proof of purchase and a copy of this warranty. The defective part(s) (or entire unit) will either be repaired or new RainSoft part(s) furnished, for a nominal charge to cover labor, handling, packing and the increase, if any, in the retail price of the part(s) since the date of purchase. Genuine RainSoft parts must be used. Failure to use genuine RainSoft parts will void the warranty and certifications.*

*This warranty does not include labor charges, and does not cover installation, transportation, or any other claims or torts. Some states do not allow the exclusion or limitation of incidental or consequential damages, so parts of the above limitation or exclusion may not apply to you.*

*This warranty gives you specific legal rights, and you may also have other rights which vary from state to state. You also have implied warranty rights. In the event of a problem with warranty service or performance, you may be able to go to a small claims court, a State court, or a Federal District Court.*

*This warranty is void if equipment is not installed and operated according to instructions. It does not apply to damage caused by abuse, accident, neglect, freezing, fire, or other abnormal conditions beyond the company's control.*

*This warranty is void on any part from which the manufacturing date has been removed or made illegible.*

*Benefits will be provided by various types of RainSoft equipment when installed and operated according to the manufacturer's recommendations. Operational, maintenance and replacement requirements are essential for the product to perform as advertised. All claims are based on the best available information at the time of printing. Manufacturer makes no representations as to the suitability of this equipment for a particular application. Buyer relies entirely on the dealer's recommendations in the purchase of this equipment.*

*Independent RainSoft dealers may include, together with your RainSoft product, a product or component that is not manufactured by RainSoft or their parent company, AWTP, LLC. Any non-RainSoft product may be covered by the manufacturer of that product, and is not covered by the RainSoft warranty. AWTP, LLC does not warrant that your RainSoft product and the non-RainSoft product will perform properly when used together, and assumes no liability therefore.*

*RainSoft Division of Aquion Water Treatment Products  
2080 East Lunt Avenue  
Elk Grove Village, Illinois 60007 USA*

## NOTES

## NOTES



RainSoft Division of Aquion Water Treatment Products  
2080 East Lunt Avenue  
Elk Grove Village, Illinois 60007  
Main Switchboard: 1.847.437.9400  
Customer Service: 1.800.860.7638  
[www.rainsoft.com](http://www.rainsoft.com)